



MTL660 Displays

Loop-powered indicators for hazardous areas

- Loop powered 4-20mA
- Field and panel mounting
- Environmental protection to IP67
- Easy to configure
- Number of displayed digits configurable
- Backlight options



The MTL661, MTL662, MTL663 and MTL665 digital indicators enable process variables to be displayed locally in hazardous and general purpose plant areas. A typical example would be the re-transmission of mass/flow computations from the safe area, through a suitable MTL IS interface to the indicator in the hazardous area.

The displays are loop powered from the 4-20mA process signal and their low voltage drop allows them to be installed in almost any 2-wire, 4-20mA transmitter loop.

All units can indicate measured values in a linear or a square root extraction mode; the latter being used, for example, to display flow from differential pressure measurement devices such as orifice plates, Dall tubes, or venturi.

The MTL661 Field mounting unit is housed in a tough aluminium enclosure, suitable for wall or pipe mounting. For corrosive atmospheres use either the MTL661-ABS or MTL663 - their plastic cases provide excellent resistance to harmful contaminants.

The MTL661-ABS can also be panel mounted by fixing the rear cover behind the panel with an additional gasket (GAS66).

The MTL665 is the panel mounted version and is IP65, IP66, IP67 and NEMA4 rated.

MTL66x IS indicators are classified as 'non-energy storing' simple apparatus so they can be inserted into any IS loop without recertification.

MTL661, MTL662 & MTL663

I.S. INDICATORS

loop powered + backlight 'B' option

The MTL66x range offers a variety of field and panel mounting IS indicators to display the current flowing in a 4–20mA loop. The small voltage drop of <1V allows the loop powered display to be installed in almost any 4–20mA loop.

Configuration is carried out using the front panel switches (which can be password protected). Range units, upper and lower limits, decimal point positioning and number of digits displayed are all configured via the front panel.

SPECIFICATION

Unit location

Zone 0, IIC, T4 hazardous area
Div 1, Group A, hazardous location

Display

5½ digits - 26mm height (process value)
Eleven 8mm digits (process units & current)

Voltage requirements under all conditions

<1V, loop powered

Ambient Temperature

Operating: -25°C to +70°C
Storage: -40°C to +80°C

Humidity

5-99%RH

Input range

4-20mA

Over-range

200mA maximum without damage

Display Range

-99999 to 199999 (Configurable)
Number of digits after decimal point configurable

Zero and span

Setting: anywhere in range

Scale direction

Normal or reverse: software selected.

Out of range indication

"---- RANGE ERROR" displayed between 3.5 - 3.75mA
"99999 RANGE ERROR" displayed at current >22mA

Operating modes

Linear or square root extraction is software selectable.

Accuracy at 20°C

± 0.01mA

Effects of temperature on accuracy

Zero: ± 0.0025% of span /°C
Span: ± 0.01% of span /°C

Ripple rejection

<0.01mA error with 1mA peak to peak ripple at 50Hz

Electrical safety

The input circuit of the indicator is designed such that it does not influence the intrinsically safe circuit to which it is connected. (In the USA the application is covered by the entity concept.)
Input circuit (terminals 4 & 5) in type of explosion protection intrinsically safe Ex ia IIC, with the following parameters:
Ui=30V, Ii=200mA, Pi=1.2W, Ci=0nF, Li=0mH only for connection to a certified intrinsically safe circuit not exceeding these values.

Backlight (see Ordering Information & final page for details)

Separately powered backlight from an IS power source
(U_o = 28V, I_o = 200mA, P_o = 0.96W max.)

Dimensions

See final page



Aluminium & GRP models



ABS model

APPROVALS

Country	Europe (ATEX)	International (IECEx)
Authority	DEKRA	DEKRA
Standards	EN 60079-0:2009 EN 60079-11:2007 EN 60079-26:2007 EN 61241-11:2006	IEC 60079-0:2007-10 IEC 60079-11:2006 IEC 60079-26:2006 IEC 61241-11:2005
Certificate /file no.	KEMA 03ATEX1194X	IECEx KEM 08.0008X
Approved for	⊕ II 1 G Ex ia IIC T4 ⊕ II 1 D Ex iaD 20 IP65/67 T 100°C Tamb = -25°C to +70°C	Ga Ex ia IIC T4 Ex iaD 20 IP65/ 67 T 100°C Tamb = -25°C to +70°C

(The maximum temperature of the enclosure, T 100°C, is referred to an ambient temperature of 70°C and is applicable to a maximum dust layer thickness of 5mm.)

ORDERING INFORMATION

When ordering a MTL661, MTL662 or MTL663 for Zone 0, use one of the following order codes to uniquely specify your requirement.

Order code	Type	Backlight	Case material	Weight g*	Case style
MTL661	Field	No	Aluminium	825	A
MTL661B	Field	Yes	Aluminium	825	A
MTL661-ABS	Field	No	ABS	375	C
MTL662	Panel	No	Aluminium	425	B
MTL662B	Panel	Yes	Aluminium	425	B
MTL663	Field	No	GRP	500	A
MTL663B	Field	Yes	GRP	500	A

* nominal

The given data is only intended as a product description and should not be regarded as a legal warranty of properties or guarantee. In the interest of further technical developments, we reserve the right to make design changes.



EUROPE (EMEA): +44 (0)1582 723633
enquiry@mtl-inst.com

THE AMERICAS: +1 800 835 7075
csinfo@mtl-inst.com

ASIA-PACIFIC: +65 6 487 7887
sales@mtlsing.com.sg

EPS660 RevF 280911

MTL665

I.S. INDICATOR

loop powered + backlight 'B' option

The MTL665 is a DIN-standard, panel mounting, IS indicator to display the current flowing in a 4–20mA loop. The small voltage drop of <1V allows the loop powered display to be installed in almost any 4–20mA loop.

Configuration is carried out using the front panel switches (which can be password protected). Range units, upper and lower limits, decimal point positioning and number of digits displayed are all configured via the front panel.

SPECIFICATION

Unit location

Zone 0, IIC, T4 hazardous area
Div 1, Group A, hazardous location

Display

5½ digits - 26mm height (process value)
Eleven 8mm digits (process units & current)

Voltage requirements under all conditions

<1V, loop powered

Ambient Temperature

Operating: -25°C to +70°C
Storage: -40°C to +80°C

Humidity

5-99%RH

Input range

4-20mA

Over-range

200mA maximum without damage

Display Range

-99999 to 199999 (Configurable)
Number of digits after decimal point configurable

Zero and span

Setting: anywhere in range

Scale direction

Normal or reverse: software selected.

Out of range indication

"---- RANGE ERROR" displayed between 3.5 - 3.75mA
"99999 RANGE ERROR" displayed at current >22mA

Operating modes

Linear or square root extraction is software selectable.

Accuracy at 20°C

± 0.01mA

Effects of temperature on accuracy

Zero: ± 0.0025% of span /°C
Span: ± 0.01% of span /°C

Ripple rejection

<0.01mA error with 1mA peak to peak ripple at 50Hz

Electrical safety

The input circuit of the indicator is designed such that it does not influence the intrinsically safe circuit to which it is connected. (In the USA the application is covered by the entity concept.)
Input circuit (terminals 4 & 5) in type of explosion protection intrinsically safe Ex ia IIC, with the following parameters:
Ui=30V, Ii=200mA, Pi=1.2W, Ci=0nF, Li=0mH only for connection to a certified intrinsically safe circuit not exceeding these values.

Backlight (see Ordering Information & final page for details)

Separately powered backlight from an IS power source
(U_o = 28V, I_o = 200mA, P_o = 0.96W max.)

Dimensions

See final page



APPROVALS

Country	Europe (ATEX)	International (IECEx)
Authority	DEKRA	DEKRA
Standards	EN 60079-0:2009 EN 60079-11:2007 EN 60079-26:2007 EN 61241-11:2006	IEC 60079-0:2007-10 IEC 60079-11:2006 IEC 60079-26:2006 IEC 61241-11:2005
Certificate /file no.	KEMA 03ATEX1194X	IECEx KEM 08.0008X
Approved for	⊕ II 1 G Ex ia IIC T4 ⊕ II 1 D Ex iaD 20 IP65/67 T 100°C Tamb = -25°C to +70°C	Ga Ex ia IIC T4 Ex iaD 20 IP65/ 67 T 100°C Tamb = -25°C to +70°C

(The maximum temperature of the enclosure, T 100°C, is referred to an ambient temperature of 70°C and is applicable to a maximum dust layer thickness of 5mm.)

ORDERING INFORMATION

When ordering a MTL665 use one of the following order codes to uniquely specify your requirement.

Order code	Type	Backlight	Case material	Weight g*	Case style
MTL665	Panel	No	Aluminium	300	D
MTL665B	Panel	Yes	Aluminium	300	D

* nominal

The given data is only intended as a product description and should not be regarded as a legal warranty of properties or guarantee. In the interest of further technical developments, we reserve the right to make design changes.



EUROPE (EMEA): +44 (0)1582 723633
enquiry@mtl-inst.com

THE AMERICAS: +1 800 835 7075
csinfo@mtl-inst.com

ASIA-PACIFIC: +65 6 487 7887
sales@mtlsing.com.sg

EPS660 RevF 280911

CASE DIMENSIONS (mm)

Style 'A'

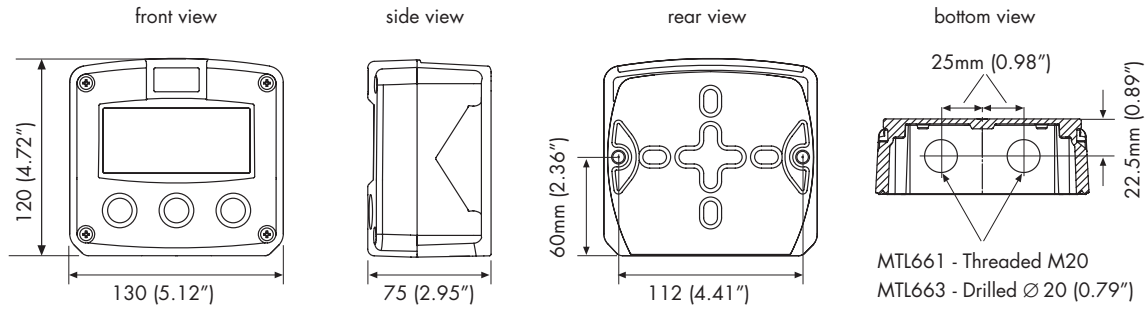

Style 'B'

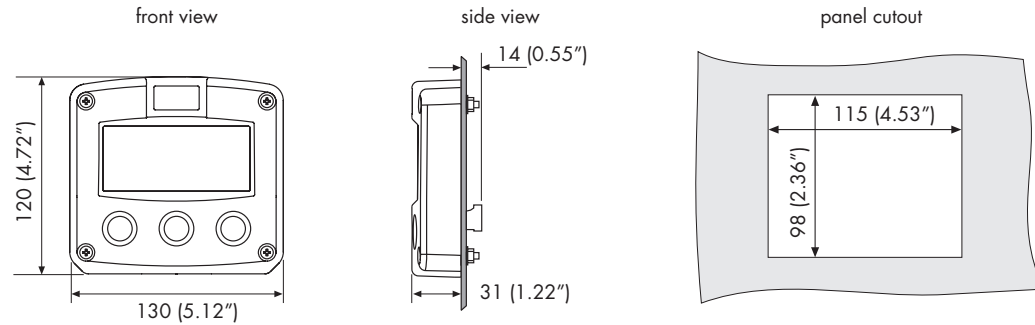

Style 'C'

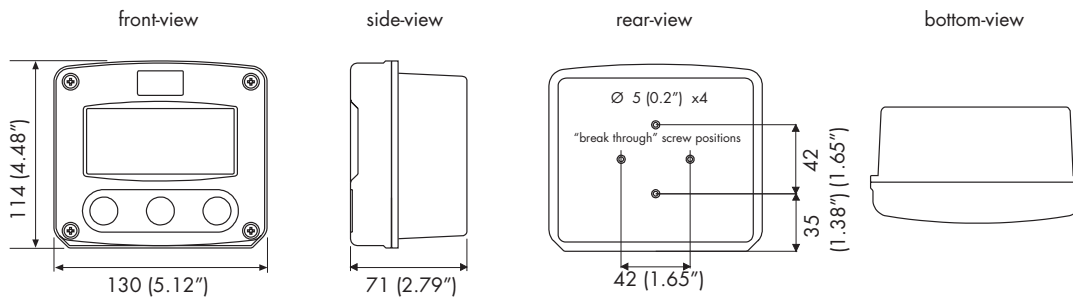

Style 'D'

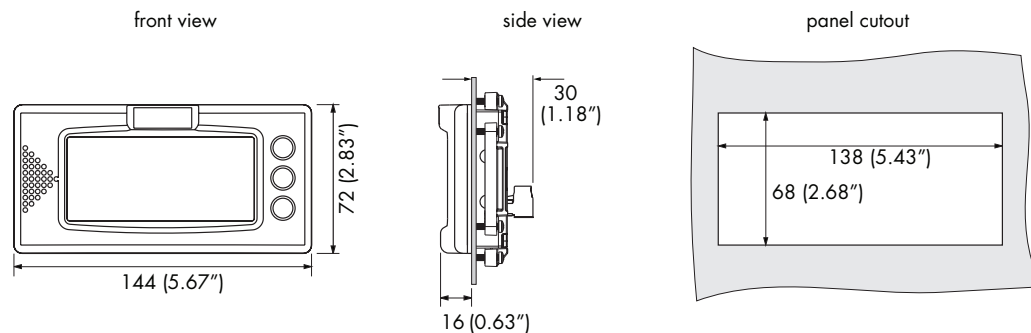

ACCESSORIES

Order code	Description	Used with
WMP66	Wall mounting plate	MTL661/663
PMA66	Pipe mounting adaptor used with WMP66	MTL661/663
PIP66-ABS	Pipe mounting kit	MTL661-ABS
PIP66	Pipe mounting kit	MTL661/663
GAS66	Spare gaskets	MTL661-ABS
GAS660	Spare gaskets - pk of 10	MTL661/663
GAS665	Spare gaskets - pk of 10	MTL665

Recommended IS interfaces for powering display

- Input circuits (in series with transmitter)
MTL5541, MTL4541, MTL7787+
- Output circuits (direct connected or in series with field device)
MTL4546Y, MTL5546Y, MTL7728P+
- Recommended IS interfaces for powering backlight
MTL5521, MTL4521, MTL7728P+

